

## D.5 CUTTING SPECIAL ANGLES

PolySteel Forms can be cut and shaped to create any design imaginable. The PS•4000 Forms are manufactured in pre-molded 45° and 90° corners, however, you can easily cut the forms to form any angle required by your design.

### D.5.1 CUTTING 90° CORNERS.

In the event that you run out of molded 90° corner forms, you can create corners in the field by following the instructions below. The measurements shown in the Table in Section D.5.2 below represent the most efficient way to create corners without creating any wasted material.

### D.5.2 CUTTING OTHER SPECIAL ANGLES.

As with mitered corners, PolySteel can be cut to achieve any angle your design requires. The following chart and illustrations below can be used as a guide for the angles listed. By marking the specified measurements (A&B) on each side of the form, a single diagonal cut will accomplish the desired angle.

#### Special Angles for PolySteel PS•4000 Walls

PolySteel Forms can be cut to form mitered corners at any angle desired. The following table and illustrations in [Figure 4.2](#) can be used as a guide for the angles listed. Mark the specified dimensions (A & B) on each side of the form and saw with a single diagonal cut. The reverse cut is required to produce opposite hand pieces to create the mitered corner without waste. The measurement "C" is the distance between the two cut lines. Alternate the corners vertically which will produce a running bond lay-up of the forms.

Angle Desired	6" Form (PS-4600)			8" Form (PS-4800)		
	A	B	C	A	B	C
5°	23-3/4"	24-1/4"	1/2"	23-3/4"	24-1/4"	1/2"
10°	23-1/2"	24-1/2"	1"	23-7/16"	24-9/16"	1-1/8"
15°	23-1/4"	24-3/4"	1-1/2"	23-1/8"	24-7/8"	1-3/4"
20°	23"	25"	2"	22-7/8"	25-1/8"	2-1/4"
22.5°	22-7/8"	25-1/8"	2-1/4"	22-11/16"	25-5/16"	2-5/8"
30°	22-1/2"	25-1/2"	3"	22-1/4"	25-3/4"	3-1/2"
36°	22-3/16"	25-13/16"	3-5/8"	21-7/8"	26-1/8"	4-1/4"
40°	22"	26"	4"	21-5/8"	26-3/8"	4-3/4"
45°	21-3/4"	26-1/4"	4-1/2"	21-5/16"	26-11/16"	5-3/8"
50°	21-7/16"	26-9/16"	5-1/8"	21"	27"	6"
60°	20-13/16"	27-3/16"	6-3/8"	"20-1/4"	27-3/4"	7-1/2"
72°	20"	28"	8"	19-1/4"	28-3/4"	9-1/2"
80°	19-3/8"	28-5/8"	9-1/4"	18-1/2"	29-1/2"	11"
90°	18-1/2"	29-1/2"	11"	17-1/2"	30-1/2"	"13"

## D.5 CUTTING SPECIAL ANGLES (continued)

FIGURE 4.2

CUTTING SPECIAL ANGLES

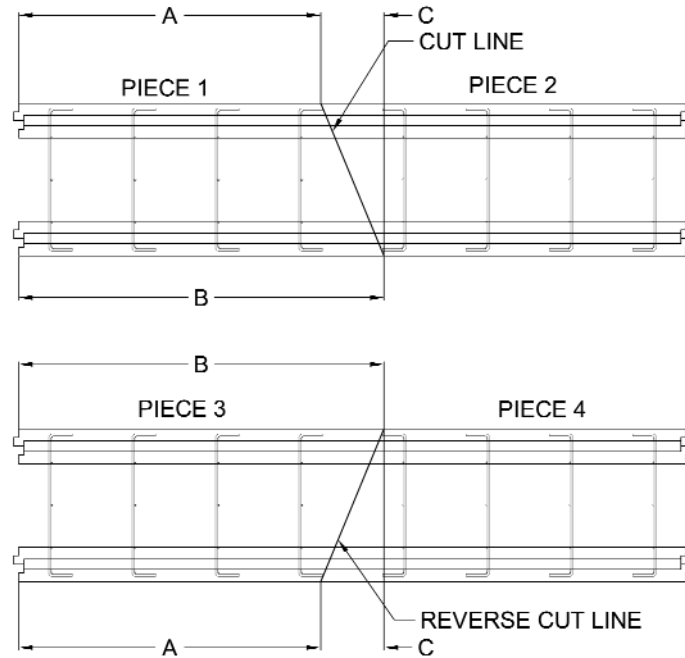

After making the required cuts at A and B, as shown above, assemble Piece 1 with Piece 4 and Piece 2 with Piece 3 to create the desired angle as shown below.

